



Benha University

Associate Prof. Mohamed Ahmed Ebrahim

Benha University
Faculty of Engineering at Shoubra
Electrical Engineering Dept.



Energy Storage & Transmission

By



Associate Prof. / Mohamed Ahmed Ebrahim Mohamed

E-mail: mohamedahmed_en@yahoo.com

mohamed.mohamed@feng.bu.edu.eg

Web site: <http://bu.edu.eg/staff/mohamedmohamed033>





Lecture (5)



Transmission
&
Distribution
&
Consumption

Associate Prof. Mohamed Ahmed Ebrahim

Concept of Energy Transmission

5

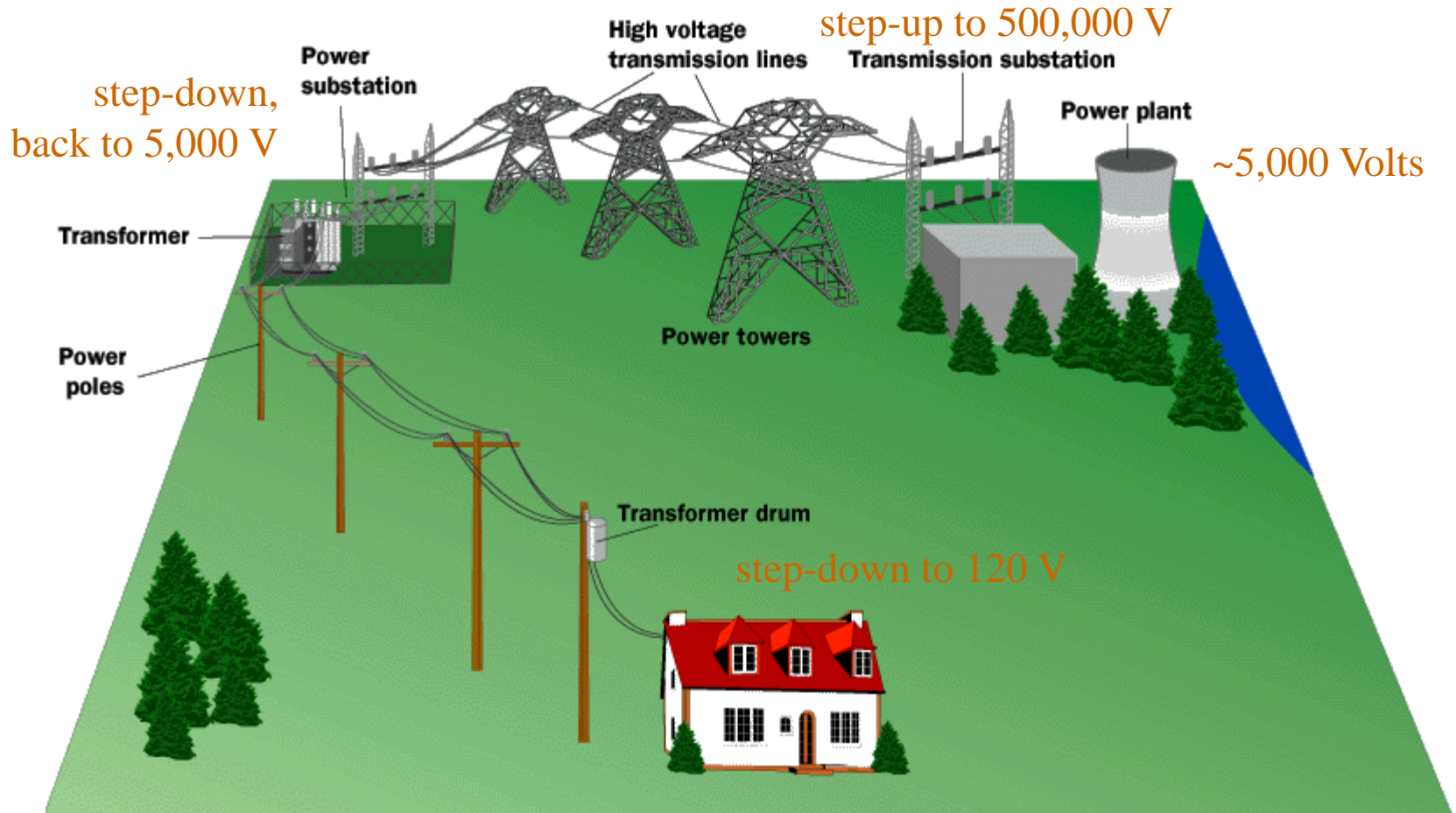

Associate Prof. Mohamed Ahmed Ebrahim

Purpose of Electrical Transmission System

6

- The purpose of the electric transmission system is the efficient interconnection of the electric energy producing power plants or generating stations with the loads.

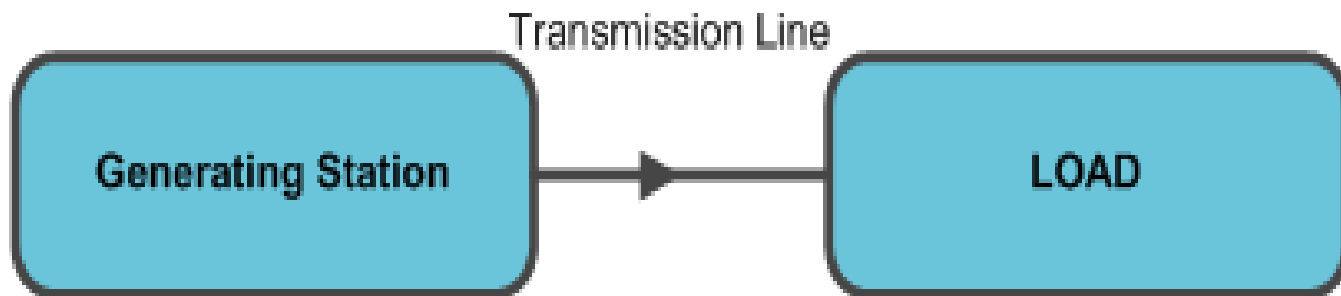

Main Parts of Power System

7

Four main parts :

Generation System



```
graph TD; A[Generation System] --> B[Transmission System]; B --> C[Distribution System]; C --> D[Consumer (LOAD)]
```

Transmission System

Distribution System

Consumer (LOAD)

Simplified Diagram of Power System

8

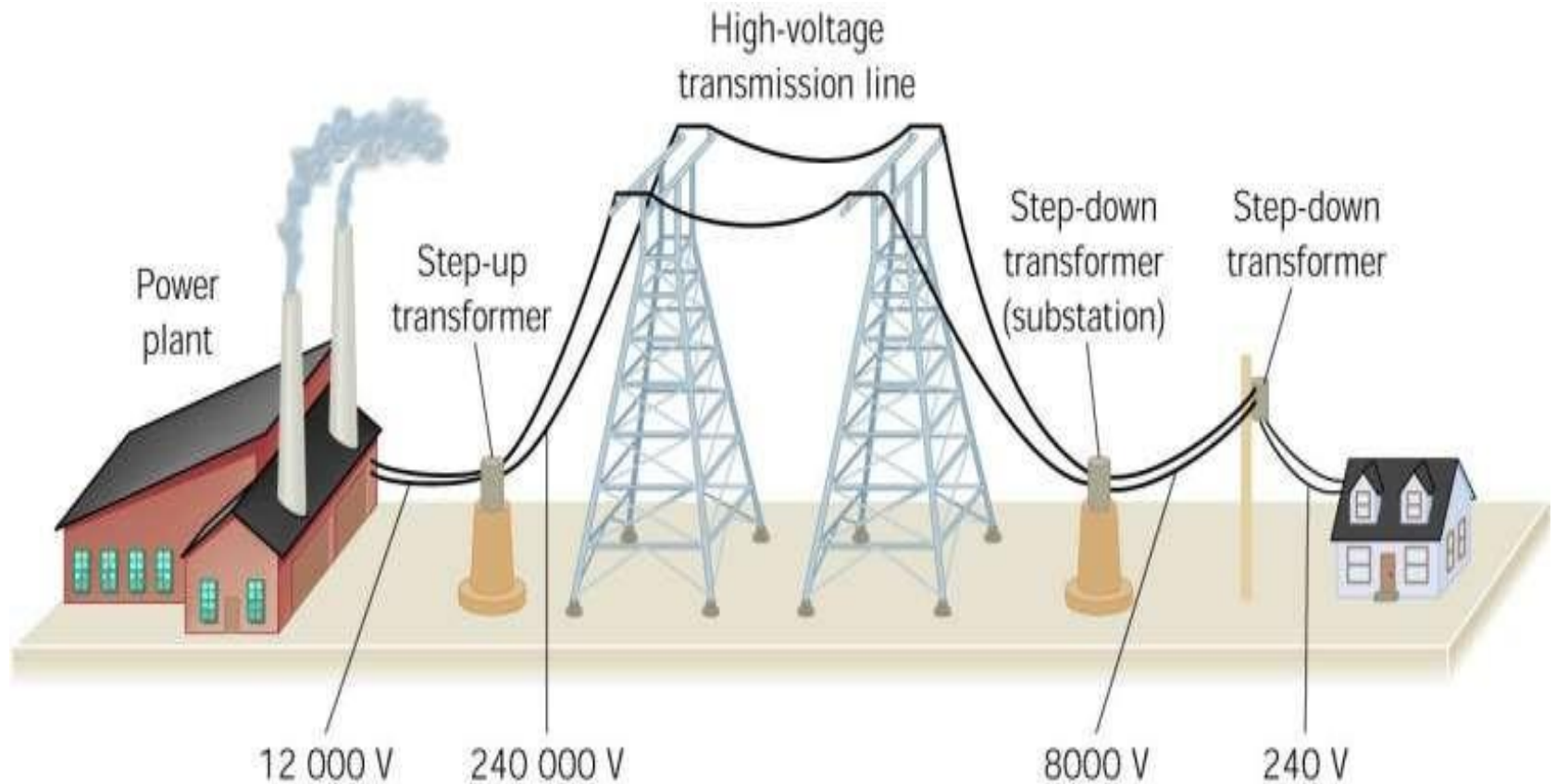

Associate Prof. Mohamed Ahmed Ebrahim

1. Generation System

- **The commonly used power plants are:**
 - A. Thermal Power Plant.
 - B. Nuclear Power Plant.
 - C. Hydro Power Plant.
 - D. Gas Turbine Power Plant.
 - E. Combined Cycle Power Plant.

Basic idea of generation

10

- Prior to the discovery of Faraday's Laws of electromagnetic, electrical power was available from batteries with limited voltage and current levels.
- For a given amount of power, the current magnitude ($I = P/V$), hence section of the copper conductor will be large.
- Thus generation, transmission and distribution of D.C power were restricted to area of few kilometer radius with no interconnections between generating plants.

One-Line Diagram of Generating Station

11

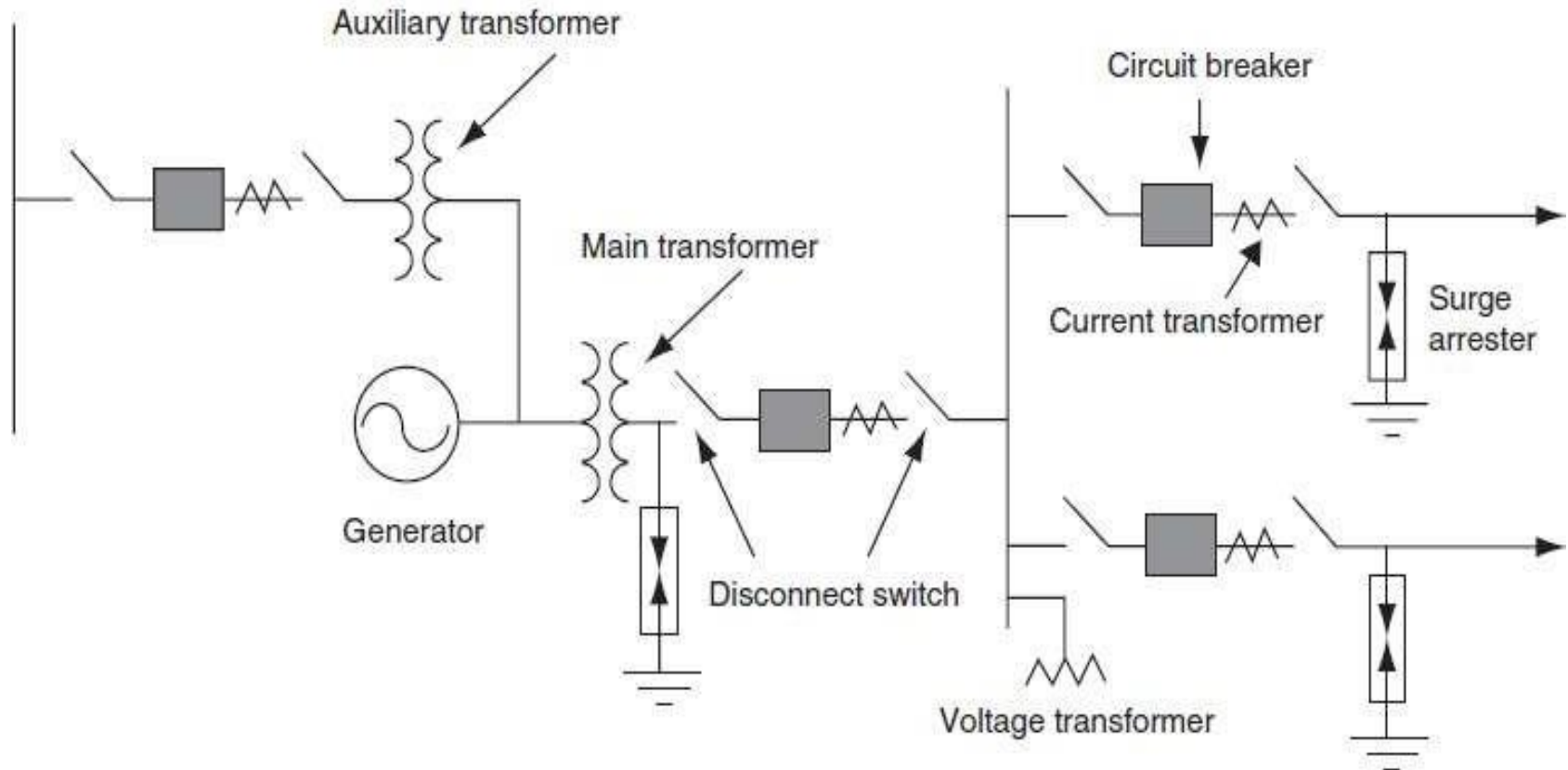

(Simplified Connection Diagram)

Main Parts of Generating Station

12

A. **Circuit Breaker (CB):**

A circuit breaker is an automatically operated electrical switch, designed to protect an electrical circuit from damage caused by fault current or short circuit

➤ **Types based on Insulators**

- I. Oil Circuit Breaker.
- II. Air Circuit Breaker.
- III. SF6 Circuit Breaker.
- IV. Vacuum Circuit Breaker.
- V.

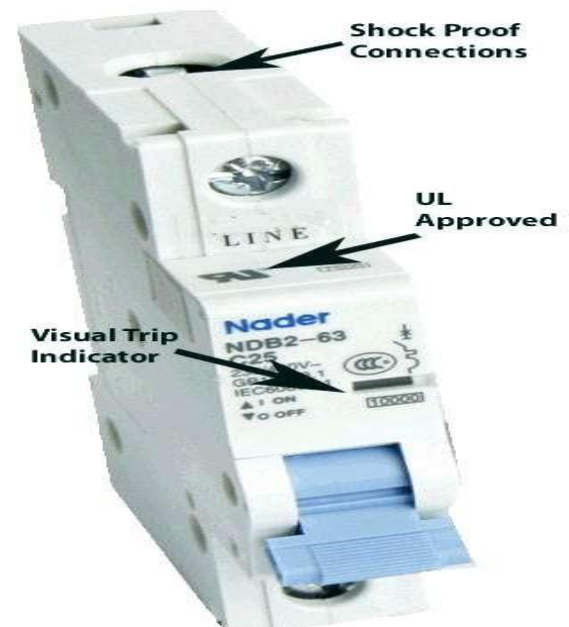

Associate Prof. Mohamed Ahmed Ebrahim

B. Disconnect Switch

Provides visible circuit separation and permits CB maintenance. It can be operated only when the CB is open i.e. in no-load condition.



c. Surge Arrester

Used for protection against lightning and switching over-voltages. They are voltage dependent, nonlinear resistors. The arrester provides a low-impedance path to ground for the current from a lightning strike or transient voltage and then restores to a normal operating condition.

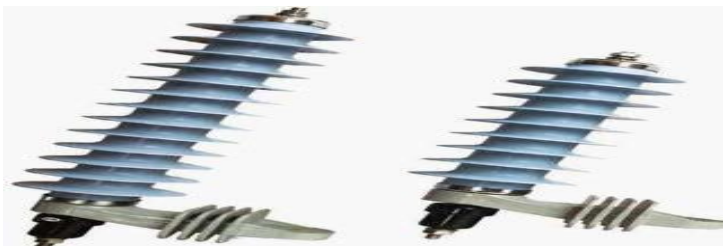

D. Current Transformers (CT) and Potential Transformers (PT)

- Used to lower the magnitude of the current and voltage to be measured.
- The CT and PT is used to solve this problem. The CT and PT works on the principle of transformer and lowers the current and/or voltage at a lower value which can be safely and easily measured.

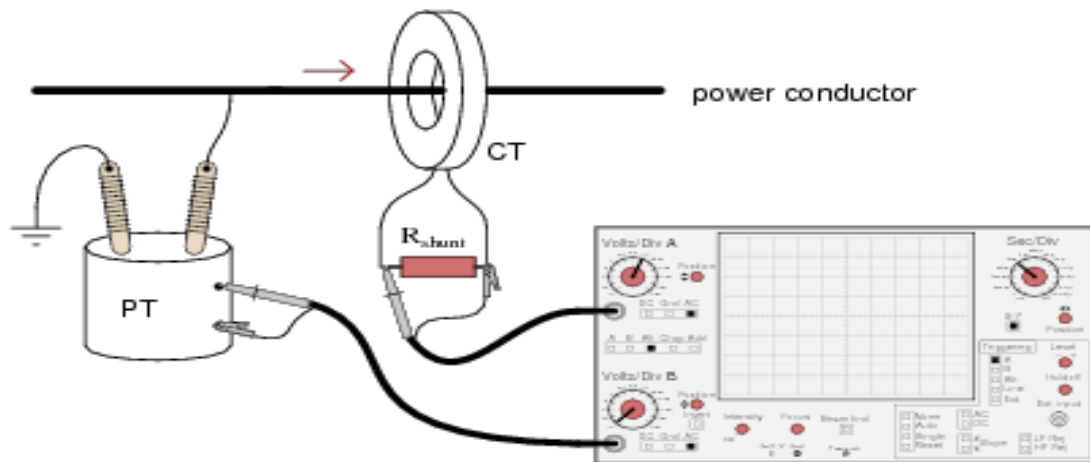

2. Transmission System

15

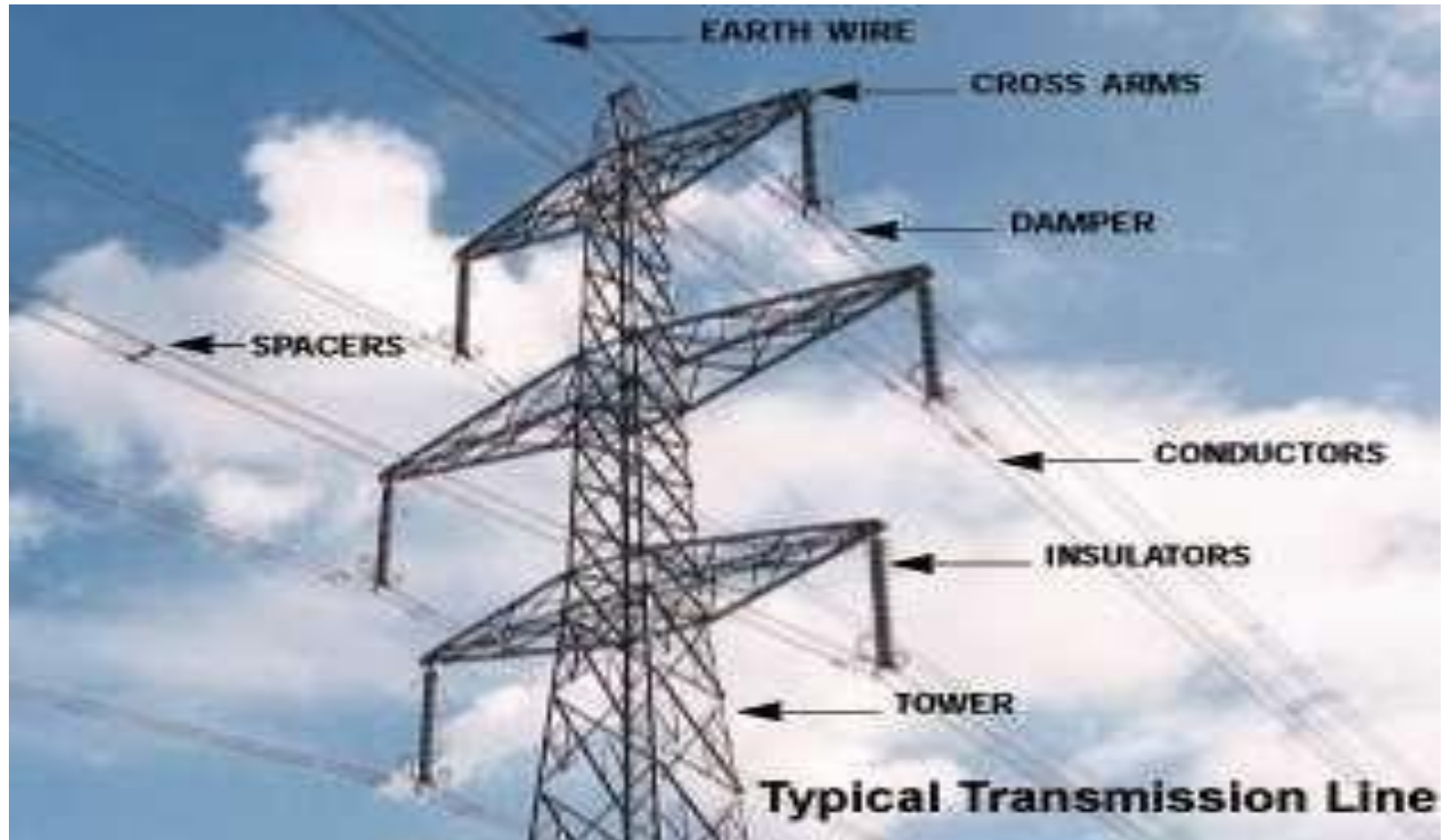

Associate Prof. Mohamed Ahmed Ebrahim

Basic idea of Transmission

16

- The huge amount of power generated in a power station (hundreds of MW) is to be transported over a long distance (hundreds of kilometers) to load centers to cater power to consumers with the help of transmission line and transmission towers.

- To give an idea, let us consider a generating station producing 120 MW power and we want to transmit it over a large distance.
- Let the voltage generated (line to line) at the alternator be 10 kV. Then to transmit 120 MW of power at 10 kV, current in the transmission line can be easily calculated by:
- For 3-phase

$$\begin{aligned}
 I &= \frac{P}{\sqrt{3} V_L \cos \theta} \text{ where } \cos \theta \text{ is the power factor} \\
 &= \frac{120 \times 10^6}{\sqrt{3} \times 10 \times 10^3 \times 0.8} \\
 \therefore I &= 8660 \text{ A}
 \end{aligned}$$

- if transmission voltage were chosen to be 400 kV, current value in the line would have been only 261.5 A.
- Standard transmission voltages used are 132 kV or 220 kV or 400 kV or 765 kV depending upon how long the transmission lines are.
- after the generator we must have a step up transformer to change the generated voltage (say 10 kV) to desired transmission voltage (say 400 kV) before transmitting it over the transmission lines.

Main Parts of Transmission Line

19

- A. **Conductor.**
- B. **Earth wire.**
- C. **Insulator.**
- D. **Transmission Tower.**

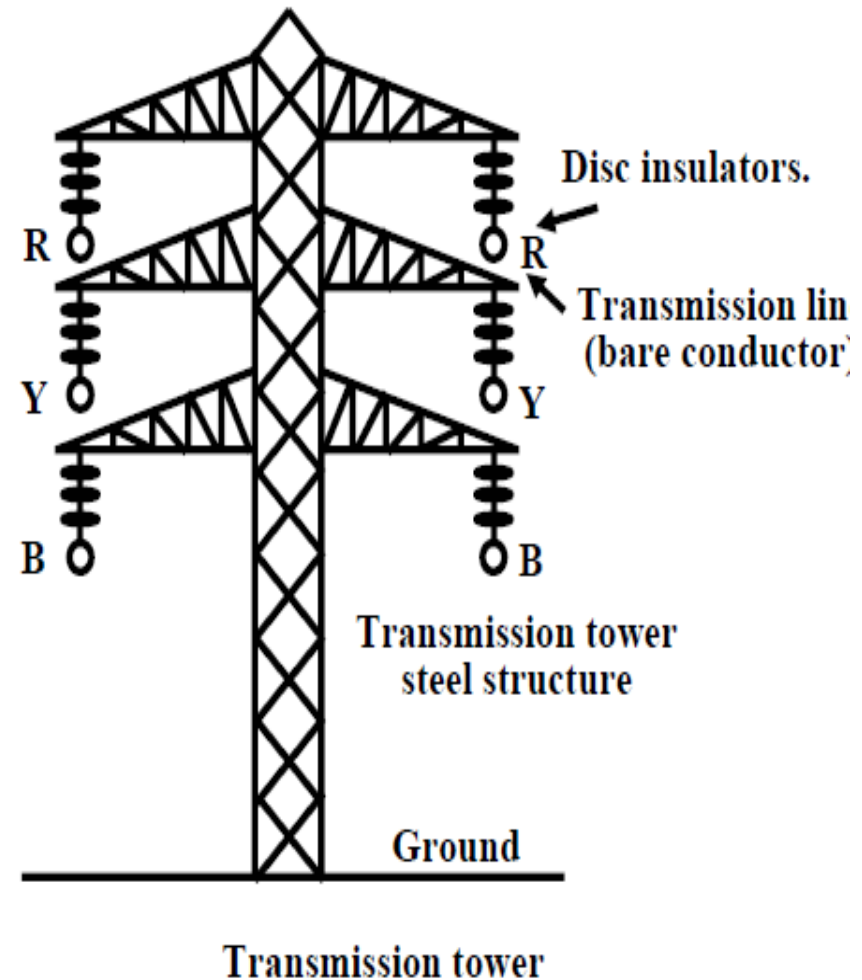

Associate Prof. Mohamed Ahmed Ebrahim

Design Methodology

20

- ❑ Gather preliminary line design data and available climatic data.
- ❑ Select reliability level in terms of return period of design.
- ❑ Calculate climatic loading on components.
- ❑ Calculate loads related to safety during construction and maintenance.
- ❑ Select appropriate correction factors, if applicable, to the design components such as use factor, strength factors related to numbers of components, quality control, and the characteristic strength.
- ❑ Design the components for the above loads and strength.

Selection of Transmission Voltage

21

- ❑ Standard Voltage: 66, 110, 132, 220, 400 KV
- ❑ Tolerances - $\pm 10\%$ up to 220 KV & $\pm 5\%$ for 400 KV
- ❑ Selection Criterion of Economic Voltage
 1. Quantum of power to be evacuated
 2. Length of line
 3. Voltage regulation
 4. Power loss in Transmission
 5. Initial and operating cost

Voltage level in a power system

22

Transmission level:

400 kV, 230 kV, 220 kV, 132 kV, 110 kV, 66 kV

Primary distribution level:

33 kV, 22 kV, 15 kV, 11 kV, 6.6 kV, 3.3 kV, 2.2 kV

Secondary distribution level:

400 V (line to line) 230 V (phase)

Transmission Line

23

- i. Overhead transmission line.
- ii. Underground transmission line.

I. Overhead transmission line

- ❑ An overhead power line is a structure used in electric power transmission and distribution to transmit electrical energy along large distances.
- ❑ It consists of one or more conductors (commonly multiples of three) suspended by towers or poles.
- ❑ Since most of the insulation is provided by air, overhead power lines are generally the lowest-cost method of power transmission for large quantities of electric energy.

II. Underground transmission line

25

- ❑ Undergrounding is the replacement of overhead cables providing electrical power or telecommunications, with underground cables.
- ❑ This is typically performed for fire prevention and to make the power lines less susceptible to outages during high wind thunderstorms or heavy snow or ice storms.
- ❑ Undergrounding can increase the initial costs of electric power transmission and distribution but may decrease operational costs over the lifetime of the cables.

Transmission Line Models and Calculations

26

- Classification of transmission lines according to line length:
 - Short transmission line ≤ 80 km
 - Medium transmission line 80 : 240 km
 - Long transmission line ≥ 240 km

Substations

27

- Substations are the places where the level of voltage undergoes change with the help of transformers.
- Apart from transformers a substation will house switches (circuit breakers), meters, relays for protection and other control equipment.
- a big substation will receive power through incoming lines at some voltage changes level of voltage using a transformer and then directs it out wards through outgoing lines.
- At the lowest voltage level of 400 V, generally 3-phase, 4-wire system is adopted for domestic connections.
- The fourth wire is called the neutral wire (N).

Associate Prof. Mohamed Ahmed Ebrahim

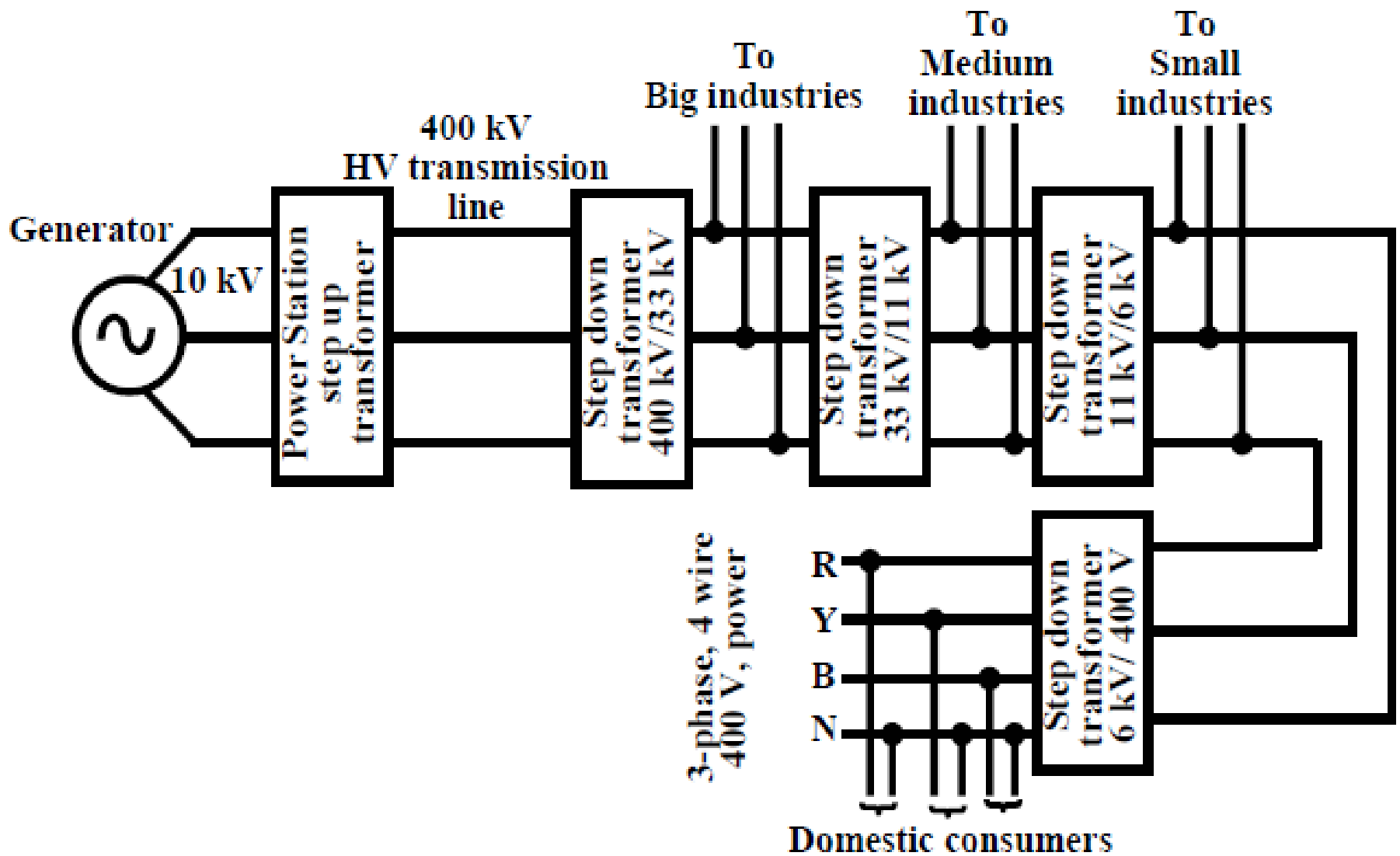

Typical voltage levels in a power system.

Associate Prof. Mohamed Ahmed Ebrahim

Single line representation of power system

29

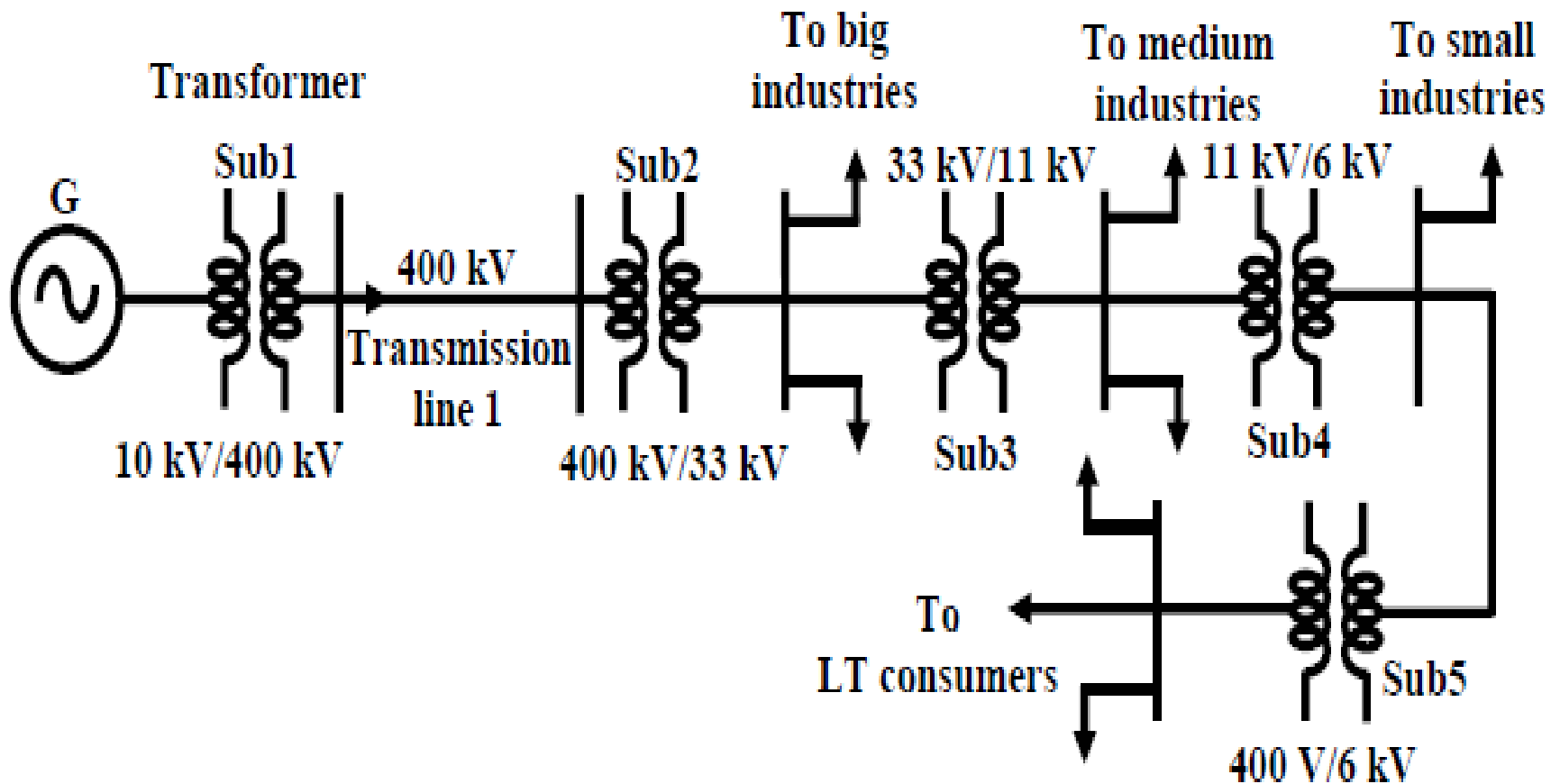

3. Distribution System

- The loads of a big city are primarily residential complexes, offices, schools, hotels, street lighting etc. These types of consumers are called LT (low tension) consumers.
- LT consumers are to be supplied with single phase, 220 V, 50 Hz. this is achieved in the substation receiving power at 33 kV.

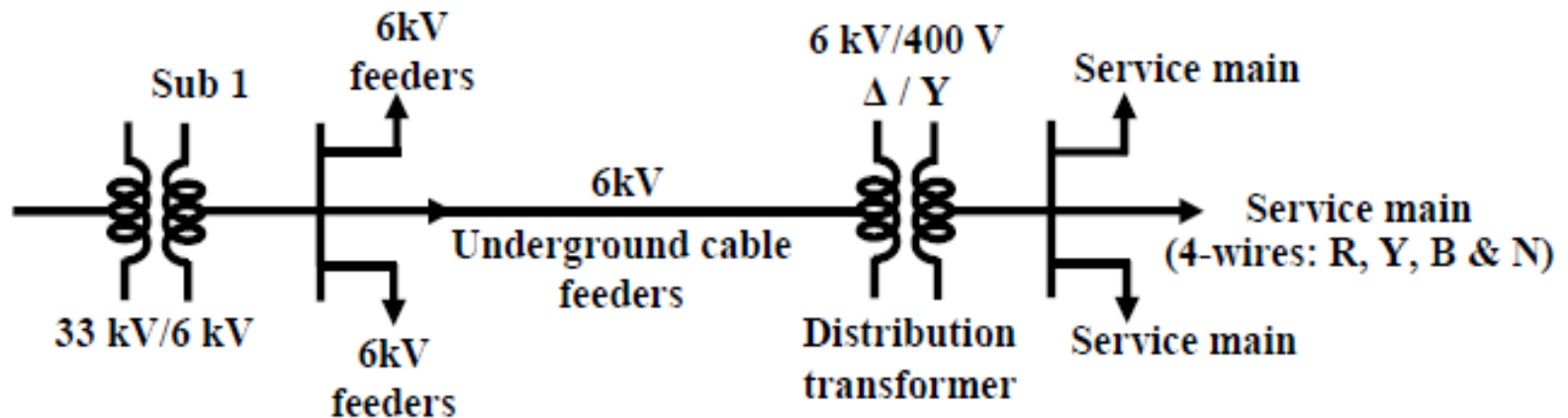

Typical Power distribution scheme.

- Power receive at a 33 kV substation is first stepped down to 6 kV and with the help of under ground cables (called feeder lines).
- power flow is directed to different directions of the city. At the last level, step down transformers are used to step down the voltage form 6 kV to 400 V.
- These transformers are called distribution transformers with 400 V, star connected secondary.
- From the secondary of these transformers 4 terminals (R, Y, B and N) come out.
- the neutral taken out from the common point of star connected secondary.
- Voltage between any two phases (i.e., R-Y, Y-B and B-R) is 400 V and between any phase and neutral is $240\text{ V}(=400/\sqrt{3})$.

4. Consumer

- At the load centers voltage level should be brought down at suitable values for supplying different types of consumers.
- Consumers may be:
 1. **Big industries**, such as steel plants.
 2. medium and small industries.
 3. offices and domestic consumers.
- Electricity is purchased by different consumers at different voltage level.